

Alliance Spacesystems, Inc.

DELIVERING THE MARS ROVER'S PRECISE ROBOTIC ARMS WITH SOLIDWORKS OFFICE

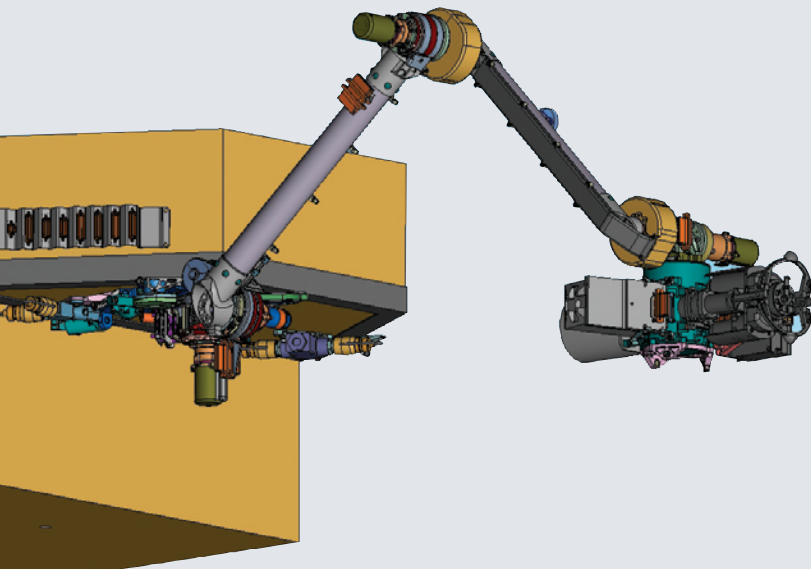

SolidWorks Office provided an integrated set of engineering and design communication tools, which streamlined communications between ASI designers, scientists, and mission planners, enabling the design team to produce an innovative, robust design under a compressed design schedule.

- Met compressed design schedule
- Increased design quality, innovation, and robustness
- Streamlined design communications, approvals
- Reduced mass in the robotic arm by 20 percent

Alliance Spacesystems, Inc. (ASI) designs and manufactures mechanical systems, robotics, structures, and mechanisms for spacecraft and scientific instruments, including the robot arms used on *Spirit* and *Opportunity*, the two rovers developed by NASA for the Mars Exploration Rover (MER) mission. When ASI began operations in 1997, the founders knew they needed a powerful yet flexible 3D CAD system to develop highly precise, complex mechanisms and collaborate with scientists and NASA mission planners, according to Brett Lindenfeld, director of engineering.

“We looked at all the high-end CAD tools, but when we looked at SolidWorks® software we immediately recognized a trailblazing software product,” Lindenfeld recalls. “SolidWorks combines the functionality of high-end CAD with an open architecture, ease of use, and access to a fully integrated set of add-on solutions to provide a complete and seamless desktop engineering system. There are no other tools that can do what SolidWorks does for the price, which was why we chose it at the very beginning.”

Overcoming time and resource challenges

The SolidWorks Office 3D CAD solution proved to be the right choice on numerous projects, Lindenfeld notes, but really showed its value during the development of robotic arms for NASA’s Mars exploration rovers, which provided the first opportunity for detailed scientific studies on Mars.

“Working with a team of eight people – a project manager, five design engineers, and two analysts – and facing incredibly challenging design constraints – including the low pressure on Mars, temperature swings from -100 to 30 degrees Celsius, the shock of landing, and restrictive space and weight requirements – we had to deliver these arms in just 18 months,” Lindenfeld explains. “Because we did not have a 100-person group and unlimited resources, we had to pursue an aggressive design process that was unlike anything we had ever done.”

“We needed a seamless, paperless concurrent design approach, and considering the time frame and scale of the effort, there was no CAD system other than SolidWorks that would have enabled us to succeed.”

Brett Lindenfeld, Director of Engineering

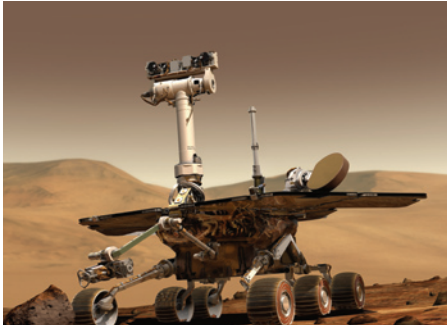

Using SolidWorks Office, ASI engineers developed the robotic arms for NASA's Mars Exploration Rover (MER) mission, which provided the first opportunity for detailed scientific studies on the Martian surface.

“I don't think this project would have been possible without SolidWorks Office and its integrated tools, such as SolidWorks Simulation software,” he adds. “Each arm has about 1,000 parts, including 300 custom parts, and at any given point we were working with as many as 50 different configurations. We needed a seamless, paperless concurrent design approach, and considering the time frame and scale of the effort, there was no CAD system other than SolidWorks that would have enabled us to succeed.”

Integrated tools boost design quality and innovation

Using SolidWorks Office, ASI accelerated design iterations and used integrated analysis capabilities to resolve problems and make the overall design more innovative and robust.

“We were searching for every gram of weight, every millimeter of space,” Lindenfeld explains. “The ability of our analysts to use the simulation software for stress and thermal analysis enabled them to backstop our designers and collaborate efficiently to optimize the design. The team was able to reduce the mass of the robotic arm by 20 percent, the automotive equivalent of the space needed for a car engine and transmission, while keeping rework to less than one percent. We were fast but still produced a higher quality, more innovative design.”

Paperless communication streamlines development

The versatile capabilities and open architecture of the SolidWorks Office suite helped ASI to finish the project with a completely paperless design documentation system. In addition to leveraging automatic drawing creation capabilities of SolidWorks software and communication capabilities in SolidWorks eDrawings®, ASI tapped the SolidWorks application programming interface (API) to develop a PDF file creation and communication tool to drive the review and approval process. The solution was so effective that ASI spun off a separate company, Bluebeam Software, Inc., to develop and market its Bluebeam Pushbutton PDF™ paperless workflow solution.

“SolidWorks Office gave us the ability to work with a truly paperless workflow,” Lindenfeld says. “The open SolidWorks API enabled us to develop an application that made the PDF file format our primary documentation tool. The flexibility of SolidWorks allowed us to use whatever communication format was required. We used SolidWorks models as well as PDF and eDrawings files – whichever format best suited the needs of each member of the development team.”

Lindenfeld adds that eliminating paper documentation kept the project on track and streamlined design communications, reviews, and approvals. “This project was all about working within a tight schedule. Using SolidWorks, we were able to complete mission-critical tasks in hours instead of weeks,” he notes.



Dassault Systèmes SolidWorks Corp.
300 Baker Avenue
Concord, MA 01742 USA
Phone: 1 800 693 9000
Outside the US: +1 978 371 5011
Email: info@solidworks.com
www.solidworks.com



Alliance Spacesystems, Inc.
1250 Lincoln Avenue, Suite 100
Pasadena, CA 91103
Phone: +1 626 296 1373
www.asi-space.com